

# SGC SERIES

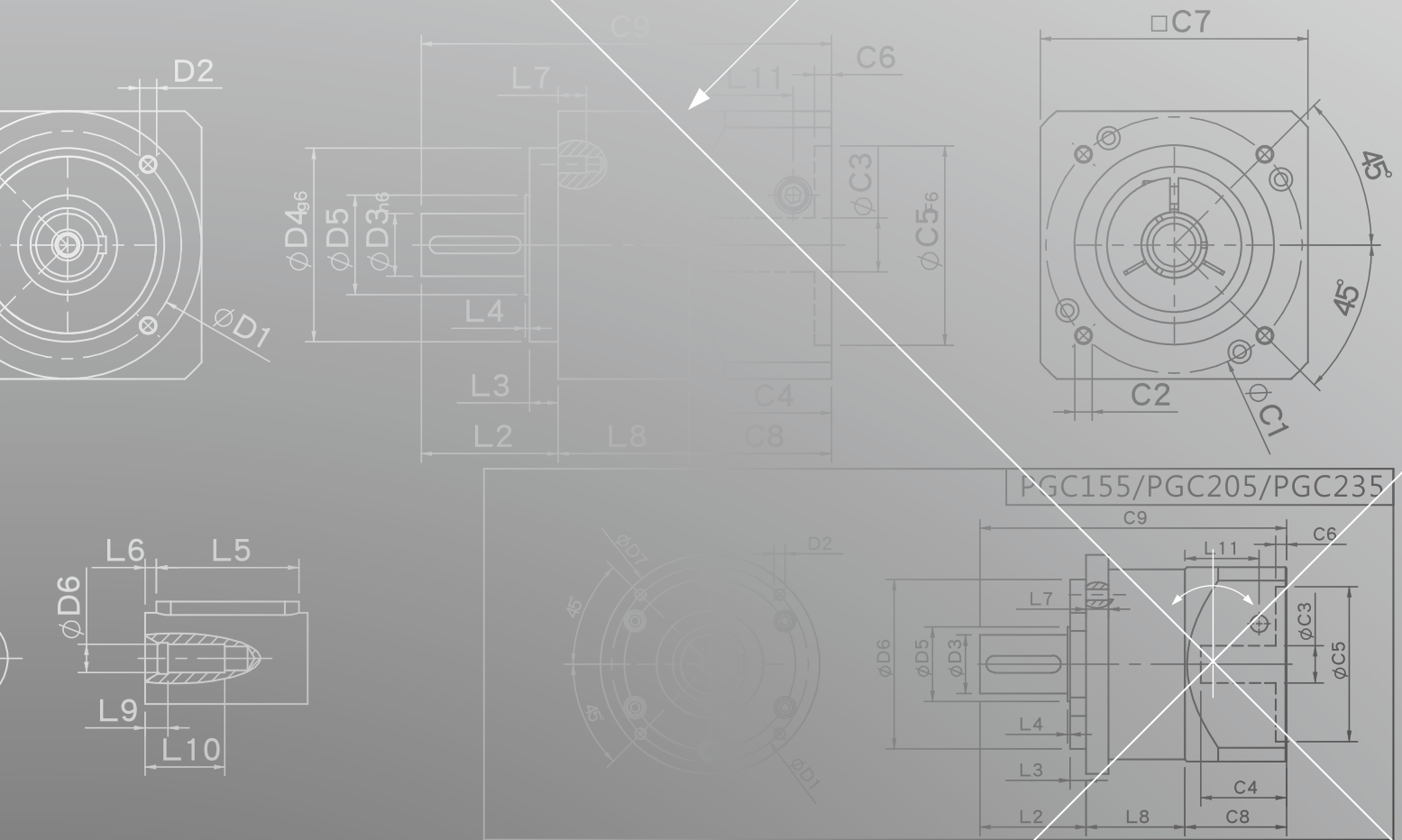

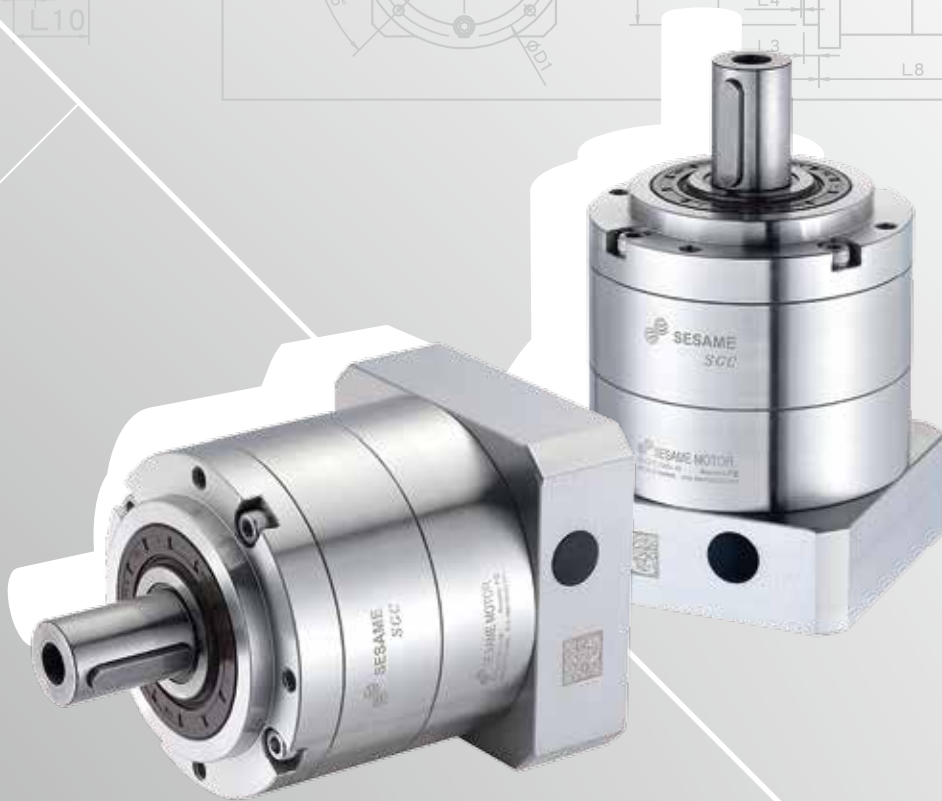

## SGC Single Stage Dimensions SGC單段外型尺寸圖

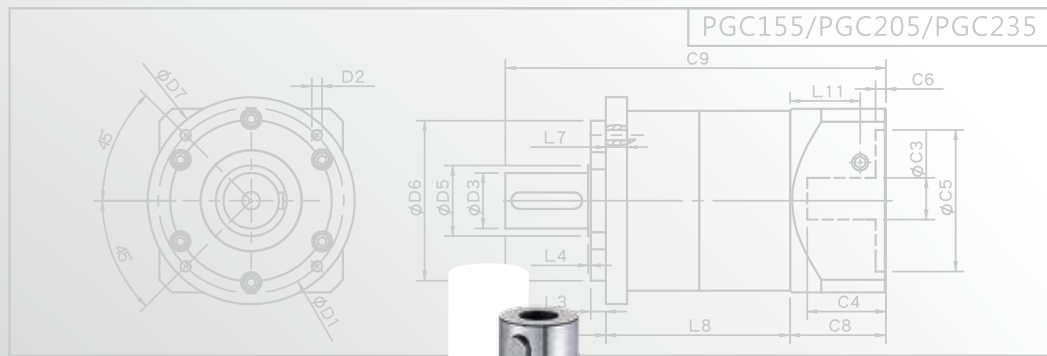
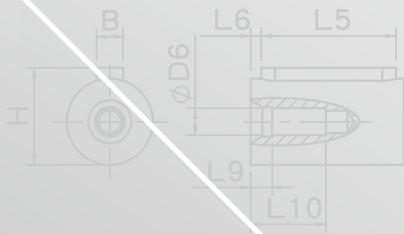
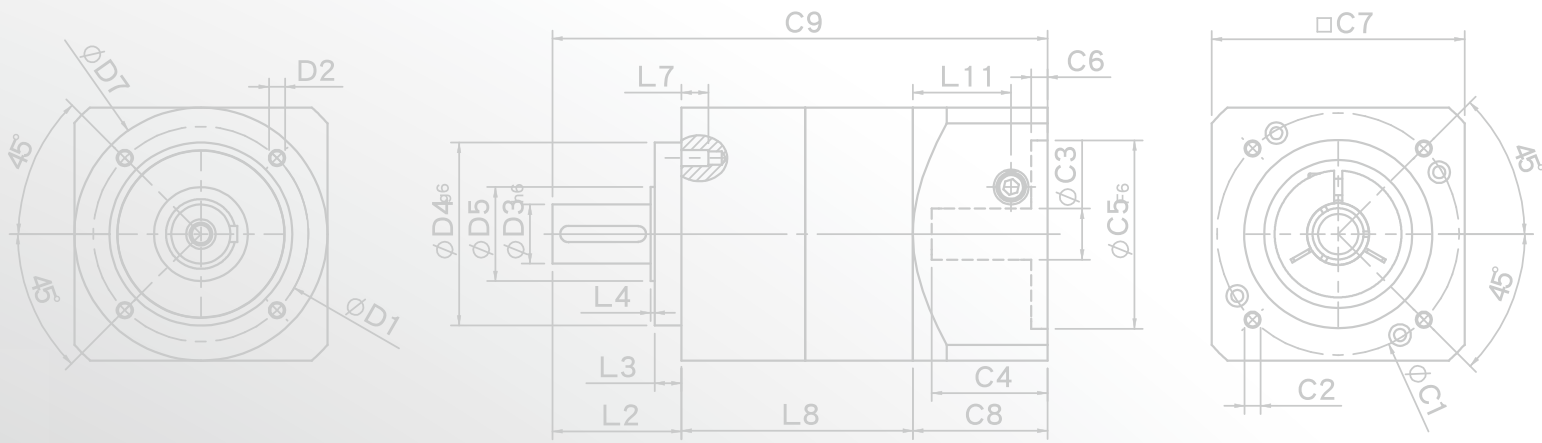
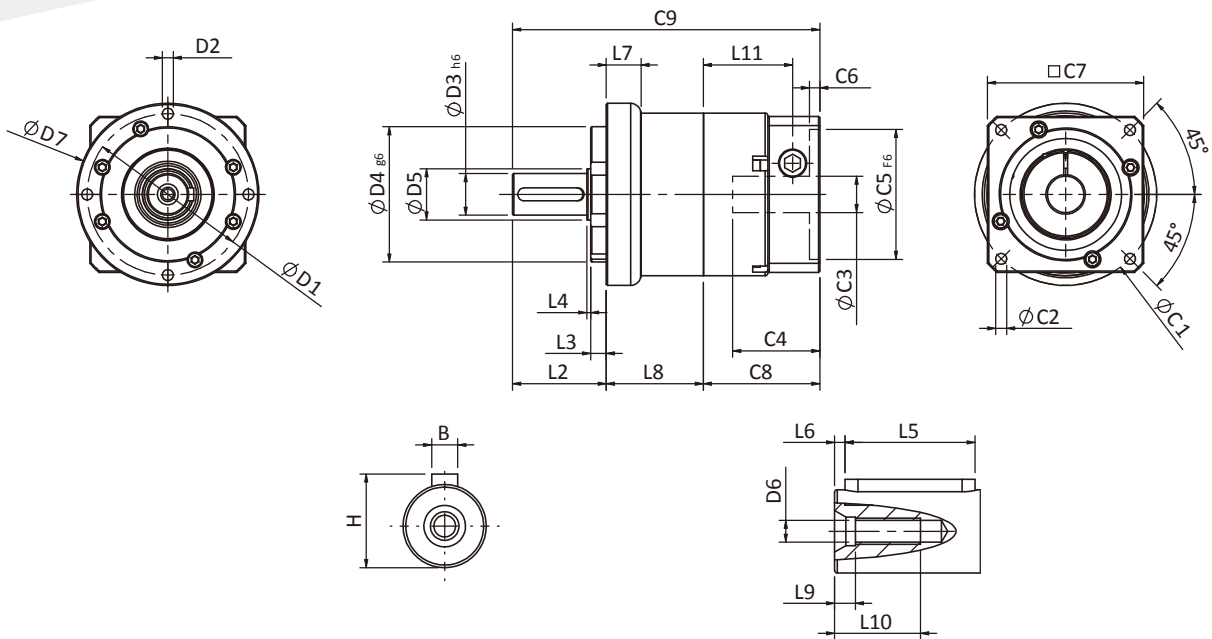

## Specifications 規格

Unit:mm

尺寸 Dimensions	SGC-50	SGC-70	SGC-90	
D1	-	62	80	
D2	-	M5x0.8P	M6x1.0P	
D3 <sub>h6</sub>	-	16	22	
D4 <sub>g6</sub>	-	52	68	
D5	-	20	35	
D6	-	M5x0.8P	M8x1.25P	
D7	-	70	90	
L2	-	36	46	
L3	-	6	7	
L4	-	1.5	2.5	
L5	-	25	32	
L6	-	2	3	
L7	-	13.4	14.1	
L8	-	37.3	43.8	
L9	-	4	4.5	
L10	-	16.5	20.5	
L11	-	34.3	41.5	
C1 <sup>2</sup>	-	70	90	
C2 <sup>2</sup>	-	M5x0.8P	M6x1.0P	
C3 <sup>2</sup>	-	≤14/≤19	≤19/≤24/≤28	
C4 <sup>2</sup>	-	33.5	41	
C5 <sup>2</sup> <sub>F6</sub>	-	50	70	
C6 <sup>2</sup>	-	4	6	
C7 <sup>2</sup>	-	60	90	
C8 <sup>2</sup>	-	44.8	55.8	
C9 <sup>2</sup>	-	118.1	145.6	
B	-	5	6	
H	-	18	24.5	

★ C1~C9是公製標準馬達連接板尺寸,請依所選用的馬達決定。

★ 本公司有權針對以上數據規格進行設計變更不先行告知。

★ C1~C9 are motor specific dimensions(metric std shown ), Size may vary according to the motor flange chosen.

★ Specification subject to change without notice.

## SGC Double Stage Dimensions SGC 雙段外型尺寸圖

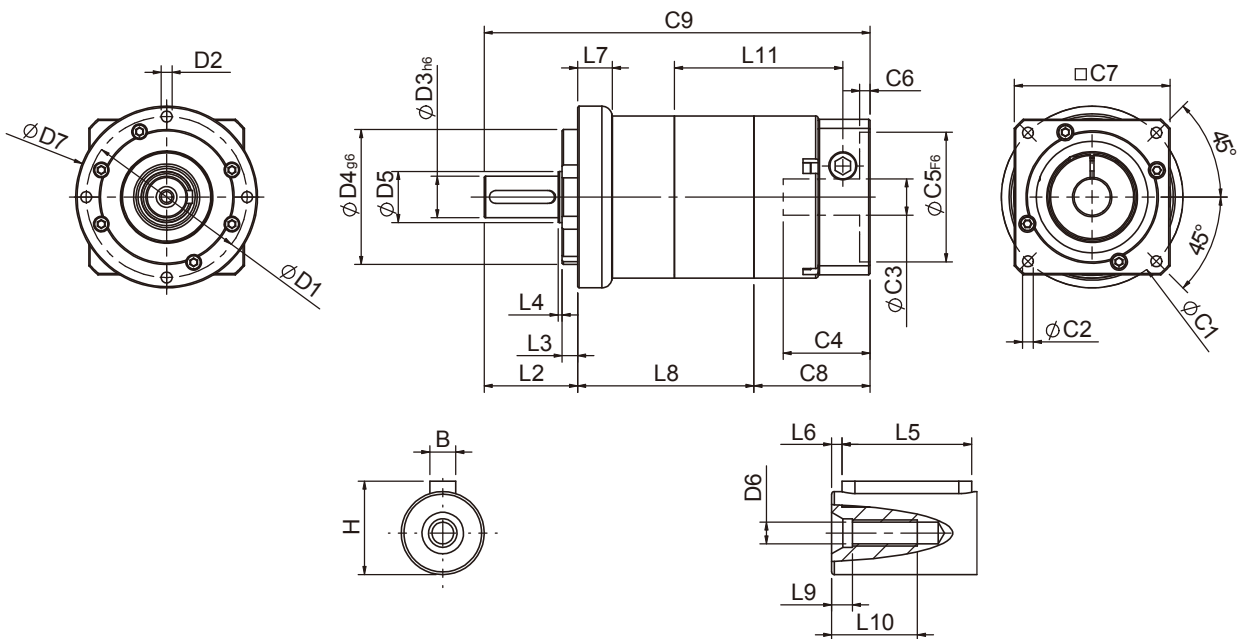

## Specifications 規格

Unit:mm

尺寸 Dimensions	SGC50	SGC70	SGC90	
D1	-	62	80	
D2	-	M5x0.8P	M6x1.0P	
D3 <sub>h6</sub>	-	16	22	
D4 <sub>g6</sub>	-	52	68	
D5	-	20	35	
D6	-	M5x0.8P	M8x1.25P	
D7	-	70	90	
L2	-	36	46	
L3	-	6	7	
L4	-	1.5	2.5	
L5	-	25	32	
L6	-	2	3	
L7	-	13.4	14.1	
L8	-	67.9	84.7	
L9	-	4	4.5	
L10	-	16.5	20.5	
L11	-	34.3	41.5	
C1 <sup>2</sup>	-	70	90	
C2 <sup>2</sup>	-	M5x0.8P	M6x1.0P	
C3 <sup>2</sup>	-	≤14/≤19	≤19/≤24/≤28	
C4 <sup>2</sup>	-	33.5	41	
C5 <sup>2</sup> <sub>F6</sub>	-	50	70	
C6 <sup>2</sup>	-	4	6	
C7 <sup>2</sup>	-	60	90	
C8 <sup>2</sup>	-	44.8	55.8	
C9 <sup>2</sup>	-	148.7	186.5	
B	-	5	6	
H	-	18	24.5	

★ C1~C9是公製標準馬達連接板尺寸,請依所選用的馬達決定。

★ 本公司有權針對以上數據規格進行設計變更不先行告知。

★ C1~C9 are motor specific dimensions(metric std shown), Size may vary according to the motor flange chosen.

★ Specification subject to change without notice.

## SGC Specifications Table SGC性能規格共表

規格 Specifications		節數 Stage	減速比 Ratio	SGC-50	SGC -70	SGC -90	SGC -120	
額定輸出力矩 $T_{2N}$ Nominal Output Torque	N · m	1	3	11	34	90	220	
			4	10	32	80	240	
			5	11	35	95	240	
			7	10	28	85	220	
			9	8	23	75	210	
			10	8	21	65	190	
		2	節數 Stage	減速比 Ratio	SGC -50	SGC -70	SGC -90	SGC -120
			15	11	35	95	168	
			20	11	35	95	240	
			25	11	35	95	240	
			35	11	35	95	240	
			45	11	35	95	240	
			49	10	28	85	220	
			63	10	28	85	220	
81	8	23	75	210				
100	8	21	65	190				
急停力矩 $T_{2NOT}$ Emergency Stop Torque	N · m	3.0 倍額定輸出力矩(3.0 times of Nominal Output Torque) (* 最大輸出力矩 Max. Output Torque $T_B = 60\%$ of Emergency Stop Torque)						
額定輸入轉速 $n_{1N}$ Nominal Input Speed	rpm	1,2	3-100	4000	4000	3000	2500	
最大輸入轉速 $n_{1max}$ Max. Input Speed	rpm	1,2	3-100	6000	6000	6000	5000	
標準背隙 Standard Backlash P2	arcmin	1	3-10	≤ 9	≤ 8	≤ 7	≤ 6	
		2	15-100	≤ 12	≤ 10	≤ 9	≤ 8	
扭轉剛性 Torsional Rigidity	N · m / arcmin	1,2	3-100	1.5	4.0	8.5	17	
容許徑向力 $F_{2RB}^1$ Max. Radial Load	N · m	1,2	3-100	760	1250	2030	4200	
容許軸向力 $F_{2AB}^1$ Max. Axial Load	N	1,2	3-100	410	700	1200	2600	
使用溫度 Operating Temp.	°C	1,2	3-100	-10°C ~ +90°C				
使用壽命 Service Life	hr	1,2	3-100	20,000 (10,000/連續運轉 Continuous operation)				
效率 Efficiency	%	1	3-10	≥ 95%				
		2	15-100	≥ 90%				
重量 Weight	kg	1	3-10	0.9	1.9	4.8	11.5	
		2	15-100	1.1	2.4	6.5	15.3	
安裝方向 Mounting Position	-	1,2	3-100	任意方向 Any direction				
噪音值 Noise Level <sup>2</sup>	dBA/1m	1,2	3-100	60	63	66	67	
防護等級 Protection Class	-	1,2	3-100	IP65				
潤滑 Lubrication	-	1,2	3-100	全合成潤滑油脂 Synthetic Lubricant				
減速機轉動慣量 Inertia(J1)								
節數 Stage	減速比 Ratio	單位 unit	SGC-50(ψ8)	SGC-70(ψ14)	SGC-90(ψ19)	SGC-120(ψ24)		
1	3	Kg · cm <sup>2</sup>	0.04	0.23	0.77	2.30		
	4		0.03	0.21	0.67	1.92		
	5~10		0.03	0.21	0.61	1.71		
節數 Stage	減速比 Ratio		SGC-50(ψ8)	SGC-70(ψ14)	SGC-90(ψ19)	SGC-120(ψ24)		
2	15		0.04	0.23	0.77	2.3		
	其它比數 Other ratios		0.03	0.21	0.67	1.92		

1. 輸出轉速 100rpm時·作用於輸出軸中心位置 Applied to the output shaft center @100rpm. 2. 3000rpm 空載量測 Measured at 3000rpm with no load.  
 ※本公司有權對以上數據規格進行設計變更不先行告知 · The above figures/specifications are subject to change without prior notice.

Products due to human error, natural disasters or other factors lead to poor or damaged, will not be covered under warranty.  
 產品因人為原因或天災等因素導致不良或損壞·不在保固範圍內。

# SGE SERIES

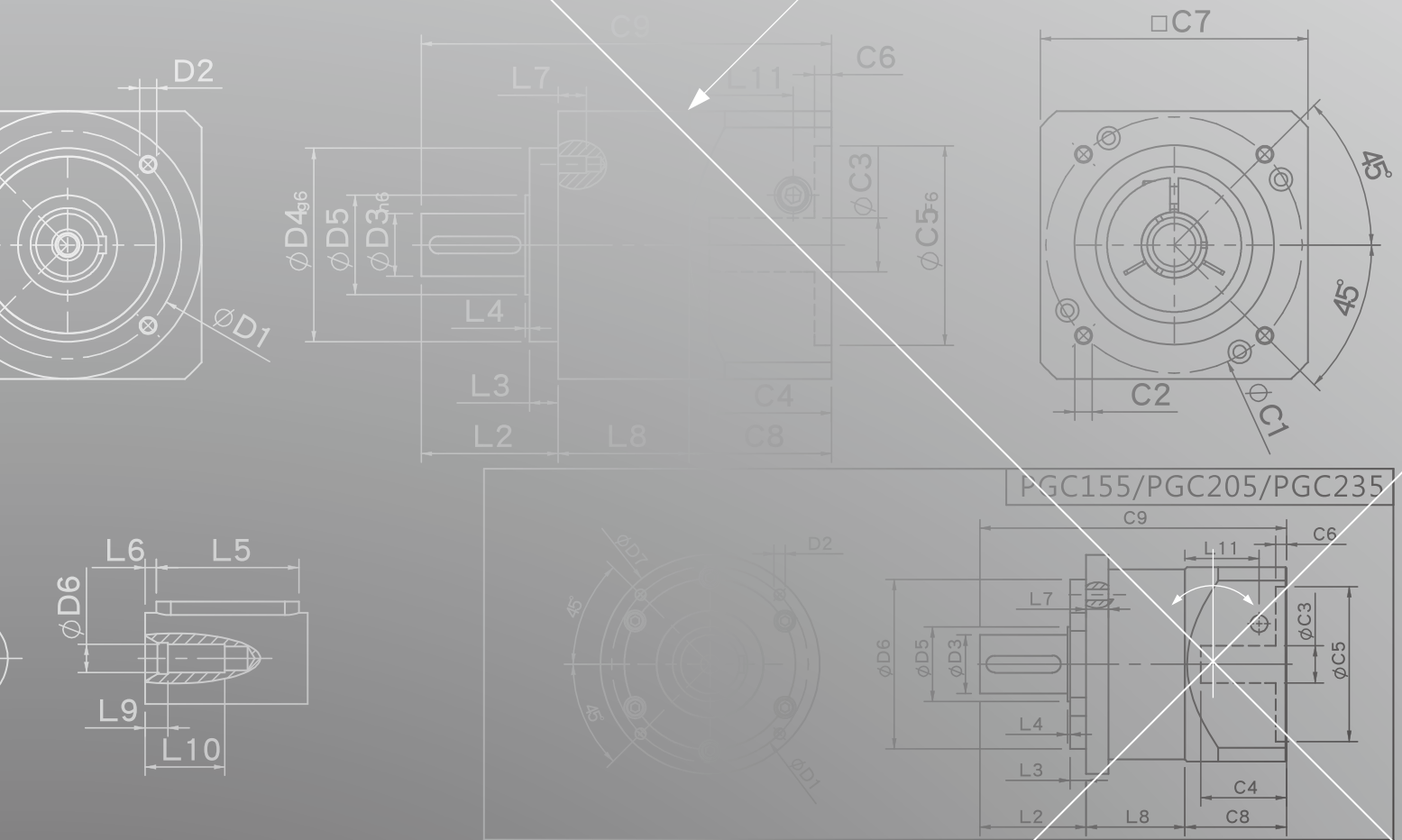

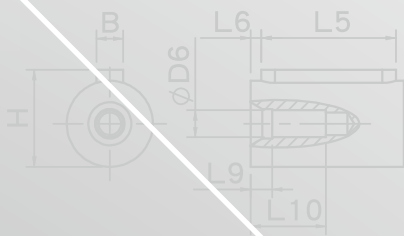
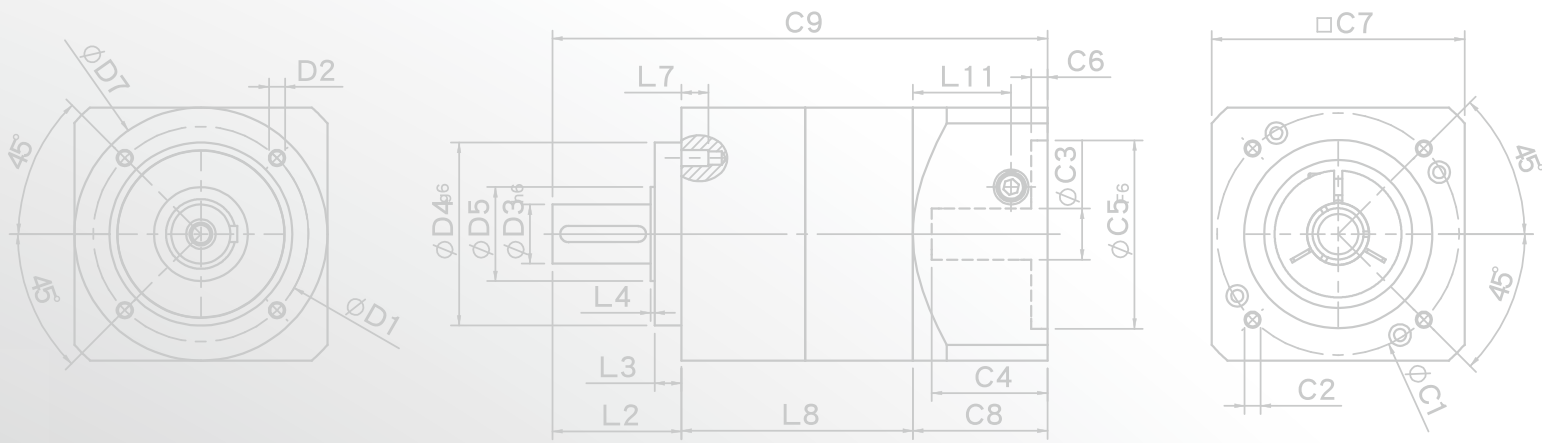

## SGE Single Stage Dimensions SGE 單段外型尺寸圖

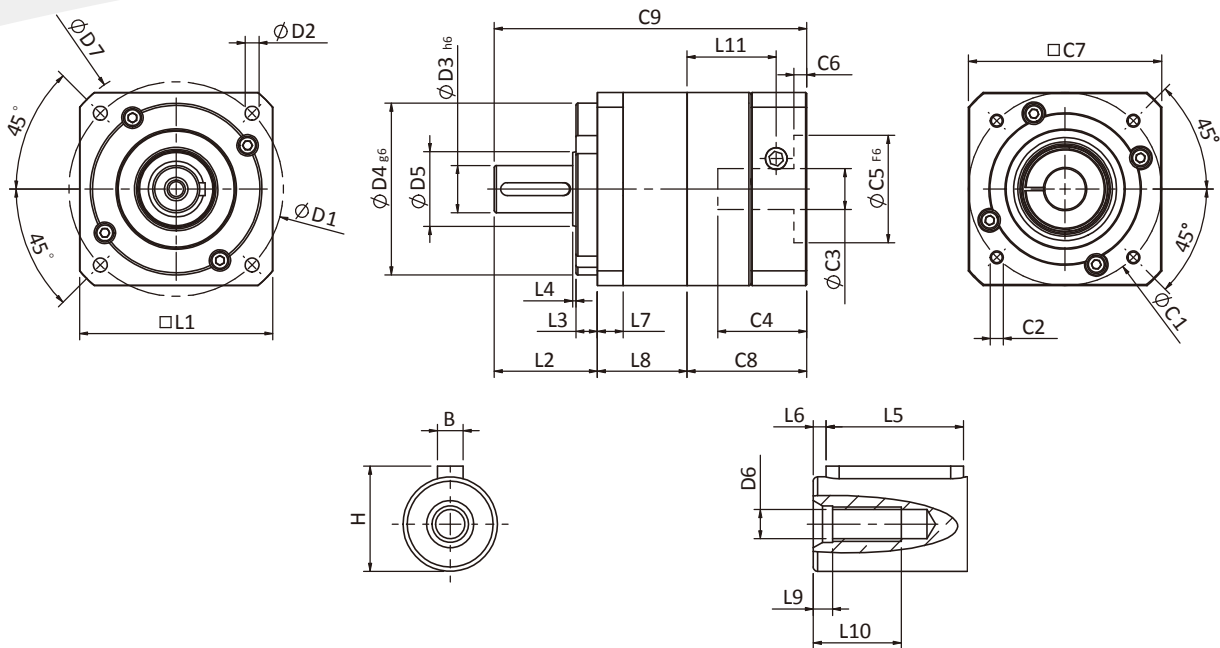

## Specifications 規格

Unit:mm

尺寸 Dimensions	SGE-42	SGE-60	SGE-90	
D1	-	70	100	
D2	-	5.5	6.5	
D3 h6	-	16	22	
D4 g6	-	50	80	
D5	-	20	35	
D6	-	M5x0.8P	M8x1.25P	
D7	-	80	118	
L1	-	62.5	90	
L2	-	37	48	
L3	-	7	10	
L4	-	1.5	1.5	
L5	-	25	32	
L6	-	2	3	
L7	-	10	12.1	
L8	-	36.3	41.8	
L9	-	4	4.5	
L10	-	16.5	20.5	
L11	-	34.3	41.5	
C1 <sup>2</sup>	-	70	90	
C2 <sup>2</sup>	-	M5x0.8P	M6x1.0P	
C3 <sup>2</sup>	-	$\leq 14 / \leq 19$	$\leq 19 / \leq 24 / \leq 28$	
C4 <sup>2</sup>	-	33.5	41	
C5 <sup>2</sup> <sub>F6</sub>	-	50	70	
C6 <sup>2</sup>	-	4	6	
C7 <sup>2</sup>	-	60	90	
C8 <sup>2</sup>	-	44.8	55.8	
C9 <sup>2</sup>	-	118.1	145.6	
B	-	5	6	
H	-	18	24.5	

★ C1~C9是公製標準馬達連接板尺寸,請依所選用的馬達決定。

★ 本公司有權針對以上數據規格進行設計變更不先行告知。

★ C1~C9 are motor specific dimensions(metric std shown), Size may vary according to the motor flange chosen.

★ Specification subject to change without notice.



## SGE Double Stage Dimensions SGE 雙段外型尺寸圖

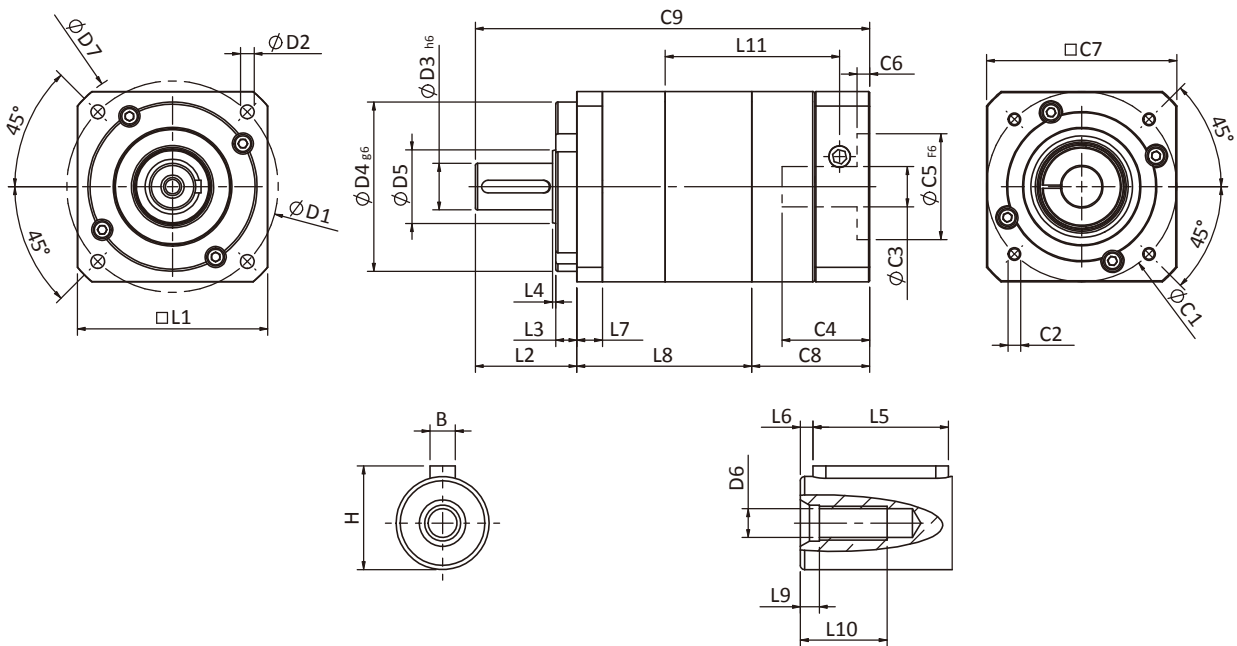

## Specifications 規格

Unit:mm

尺寸 Dimensions	SGE-42	SGE-60	SGE-90	
D1	-	70	100	
D2	-	5.5	6.5	
D3 <sub>h6</sub>	-	16	22	
D4 <sub>g6</sub>	-	50	80	
D5	-	20	35	
D6	-	M5x0.8P	M8x1.25P	
D7	-	80	118	
L1	-	62.5	90	
L2	-	37	48	
L3	-	7	10	
L4	-	1.5	1.5	
L5	-	25	32	
L6	-	2	3	
L7	-	10	12.1	
L8	-	66.9	82.7	
L9	-	4	4.5	
L10	-	16.5	20.5	
L11	-	34.3	41.5	
C1 <sup>2</sup>	-	70	90	
C2 <sup>2</sup>	-	M5x0.8P	M6x1.0P	
C3 <sup>2</sup>	-	≤14/≤19	≤19/≤24/≤28	
C4 <sup>2</sup>	-	33.5	41	
C5 <sup>2</sup> <sub>F6</sub>	-	50	70	
C6 <sup>2</sup>	-	4	6	
C7 <sup>2</sup>	-	60	90	
C8 <sup>2</sup>	-	44.8	55.8	
C9 <sup>2</sup>	-	148.7	186.5	
B	-	5	6	
H	-	18	24.5	

★ C1~C9是公製標準馬達連接板尺寸,請依所選用的馬達決定。

★ 本公司有權針對以上數據規格進行設計變更不先行告知。

★ C1~C9 are motor specific dimensions(metric std shown), Size may vary according to the motor flange chosen.

★ Specification subject to change without notice.

## SGE Specifications Table SGE 性能規格共表

規格 Specifications		節數 Stage	減速比 Ratio	SGE-42	SGE-60	SGE-90	SGE-115
額定輸出力矩 $T_{2N}$ Nominal Output Torque	N · m	1	3	11	34	90	220
			4	10	32	80	240
			5	11	35	95	240
			7	10	28	85	220
			9	8	23	75	210
			10	8	21	65	190
		2	減速比 Ratio	SGE-42	SGE-60	SGE-90	SGE-115
			15	11	35	95	168
			20	11	35	95	240
			25	11	35	95	240
			35	11	35	95	240
			45	11	35	95	240
			49	10	28	85	220
			63	10	28	85	220
81	8	23	75	210			
100	8	21	65	190			
急停力矩 $T_{2NOT}$ Emergency Stop Torque	N · m	3.0 倍額定輸出力矩(3.0 times of Nominal Output Torque) (* 最大輸出力矩 Max. Output Torque $I_B = 60\%$ of Emergency Stop Torque)					
額定輸入轉速 $n_{1N}$ Nominal Input Speed	rpm	1,2	3-100	4000	4000	3000	2500
最大輸入轉速 $n_{1max}$ Max. Input Speed	rpm	1,2	3-100	6000	6000	6000	5000
標準背隙 Standard Backlash P2	arcmin	1	3-10	≤ 9	≤ 8	≤ 7	≤ 6
		2	15-100	≤ 12	≤ 10	≤ 9	≤ 8
扭轉剛性 Torsional Rigidity	N · m / arcmin	1,2	3-100	1.5	4.0	8.5	17
容許徑向力 $F_{2RB}^1$ Max. Radial Load	N · m	1,2	3-100	760	1250	2030	4200
容許軸向力 $F_{2AB}^1$ Max. Axial Load	N	1,2	3-100	410	700	1200	2600
使用溫度 Operating Temp.	°C	1,2	3-100	-10°C ~ +90°C			
使用壽命 Service Life	hr	1,2	3-100	20,000 (10,000/連續運轉 Continuous operation)			
效率 Efficiency	%	1	3-10	≥ 95%			
		2	15-100	≥ 90%			
重量 Weight	kg	1	3-10	0.9	1.9	4.8	11.5
		2	15-100	1.1	2.4	6.5	15.3
安裝方向 Mounting Position	-	1,2	3-100	任意方向 Any direction			
噪音值 Noise Level <sup>2</sup>	dBA/1m	1,2	3-100	60	63	66	67
防護等級 Protection Class	-	1,2	3-100	IP65			
潤滑 Lubrication	-	1,2	3-100	全合成潤滑油脂 Synthetic Lubricant			
減速機轉動慣量 Inertia(J1)							
節數 Stage	減速比 Ratio	單位 unit	SGE-42(ψ8)	SGE-60(ψ14)	SGE-90(ψ19)	SGE-115(ψ24)	
1	3	Kg · cm <sup>2</sup>	0.04	0.23	0.77	2.30	
	4		0.03	0.21	0.67	1.92	
	5~10		0.03	0.21	0.61	1.71	
節數 Stage	減速比 Ratio		SGE-42(ψ8)	SGE-60(ψ14)	SGE-90(ψ19)	SGE-115(ψ24)	
2	15		0.04	0.23	0.77	2.3	
	其它比數 Other ratios		0.03	0.21	0.67	1.92	

1. 輸出轉速 100rpm 時，作用於輸出軸中心位置 Applied to the output shaft center @100rpm. 2. 3000rpm 空載量測 Measured at 3000rpm with no load.  
 ※本公司有權對以上數據規格進行設計變更不先行告知。The above figures/specifications are subject to change without prior notice.

Products due to human error, natural disasters or other factors lead to poor or damaged, will not be covered under warranty.  
 產品因人為原因或天災等因素導致不良或損壞，不在保固範圍內。